

# VIZULO Blackbird top entry LED street luminaire

Mounting instruction Montāžas instrukcija Монтажная инструкция

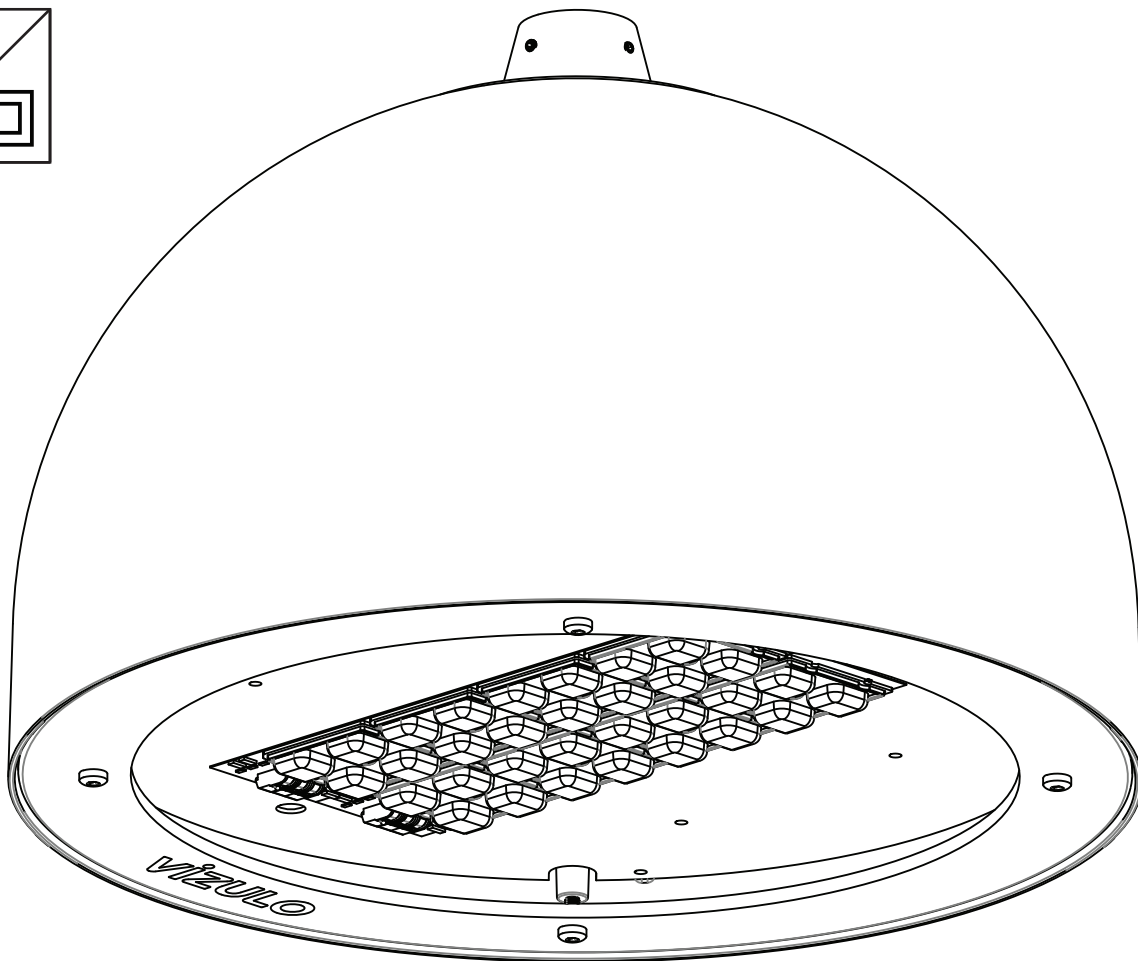

- \* Depends on configuration. Check label or technical specification.
- \* Atkarīgs no konfigurācijas. Skatīt marķējumu vai tehnisko specifikāciju.
- \* Зависит от конфигурации. Смотреть маркировку или техническую спецификацию.

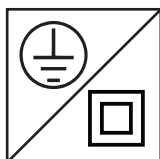
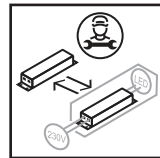
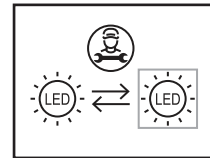
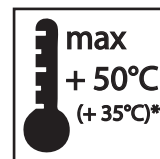
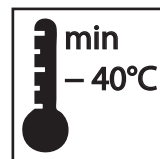

**Dimensions**  
**Izmēri**  
**Размеры**

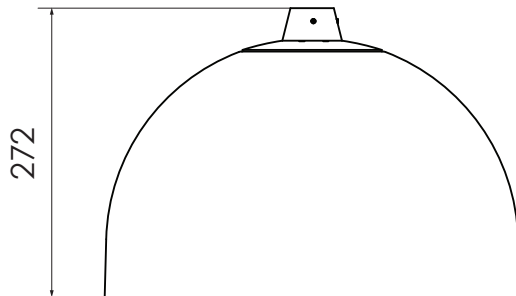
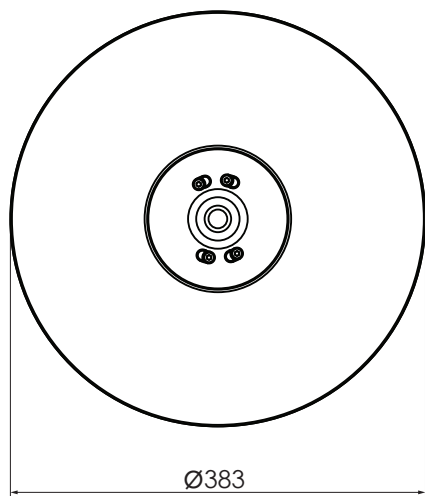

SCd = 0.09 m<sup>2</sup>

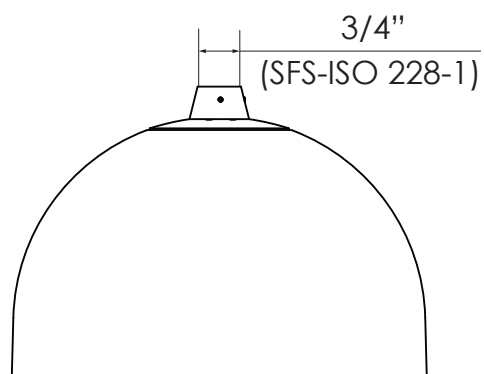
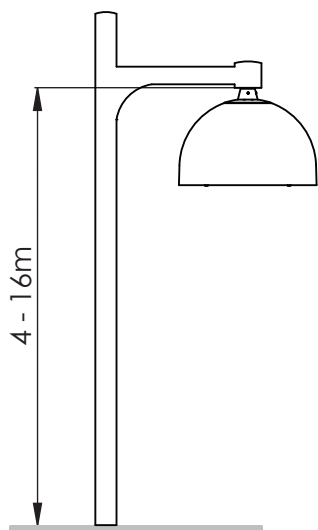

**Average Netto Weight | Vidējais Neto Svars | Средний Нетто Вес**

BBA: [ ] [ ] [ ] [ ] BG032 [ ] [ ] [ ]

8.1 Kg

Direction of light for asymmetric lens  
Gaismas virziens asimetriskām lēcām  
Направление света для асимметричных линз

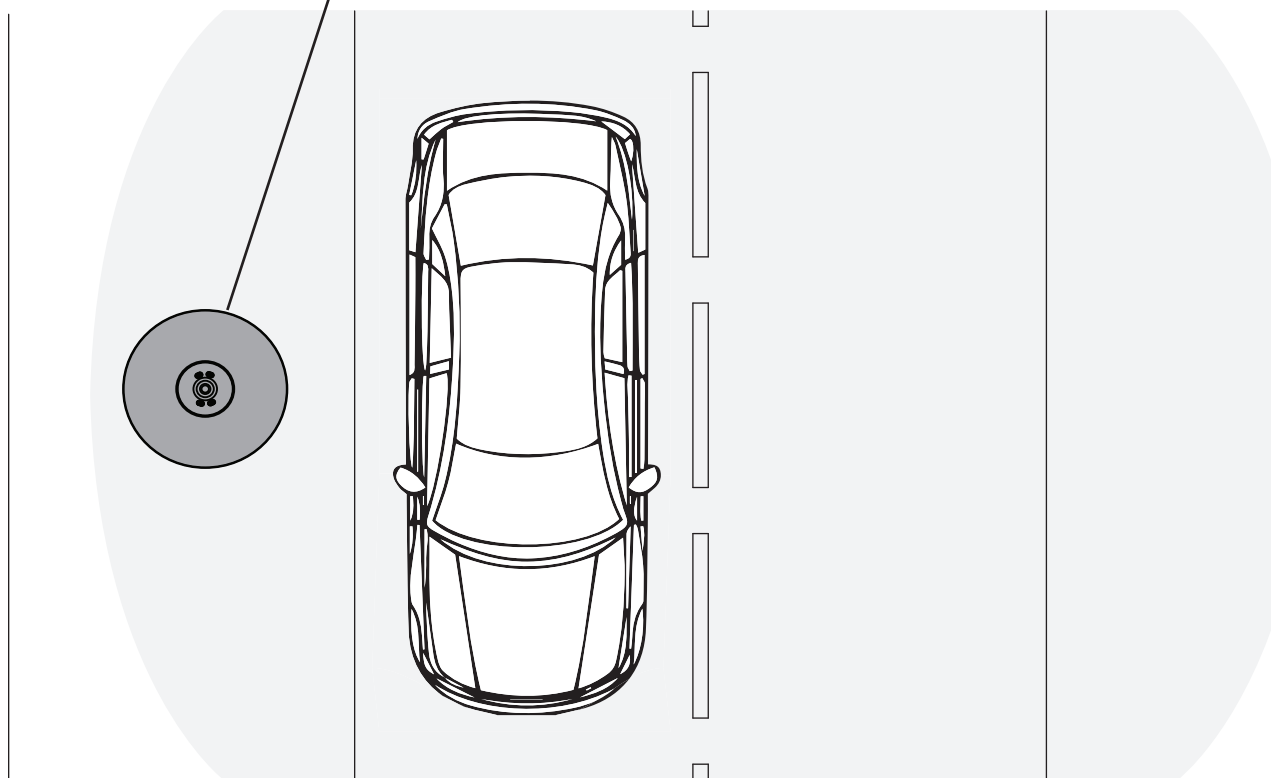
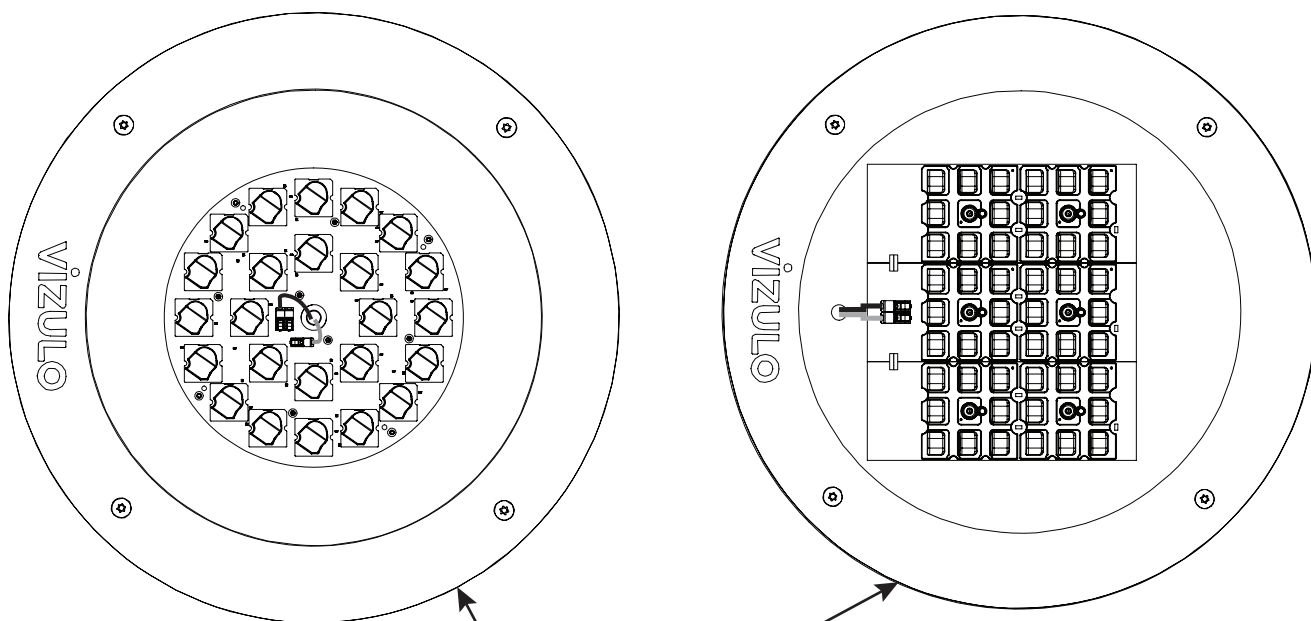

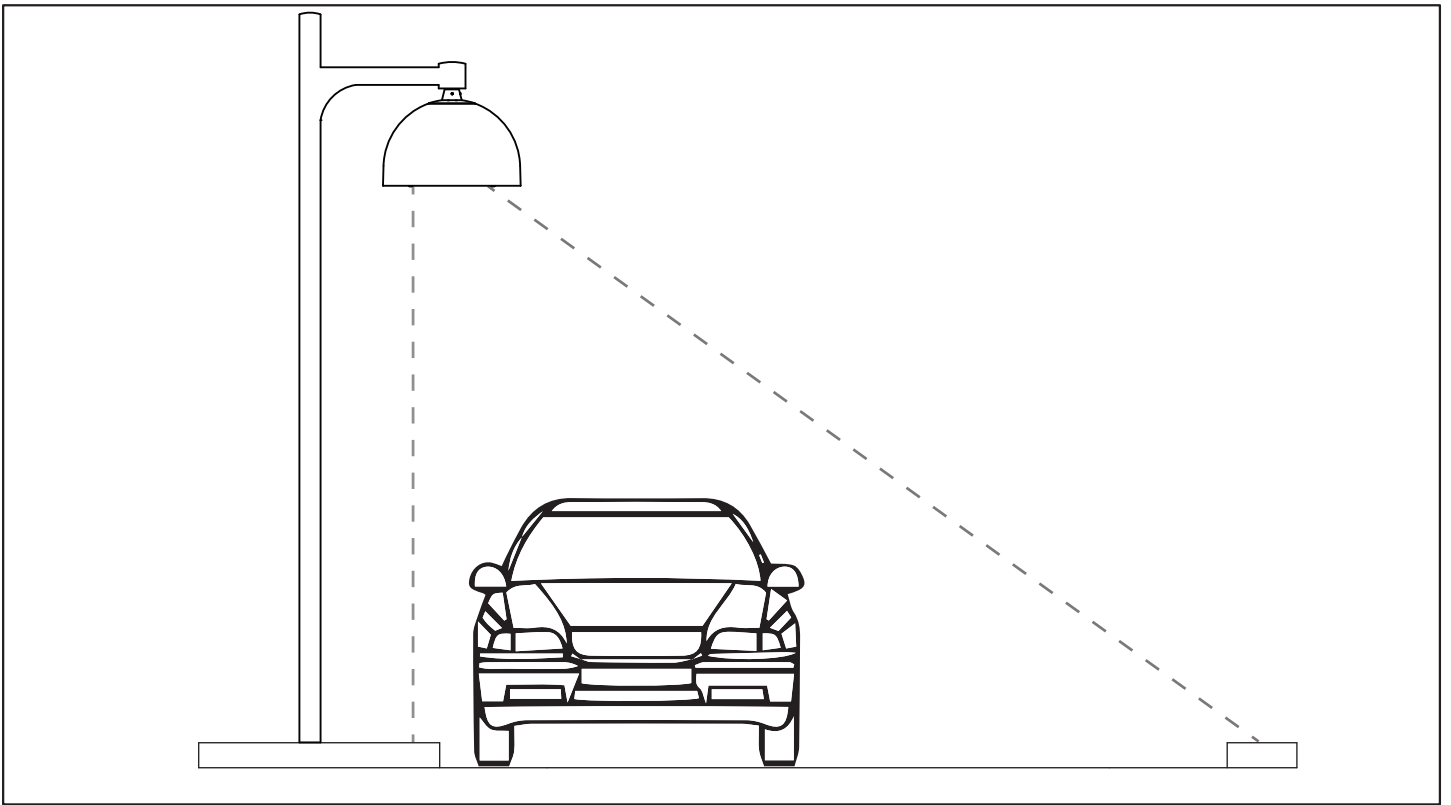

Acceptable luminaire mounting angle relative to the ground.

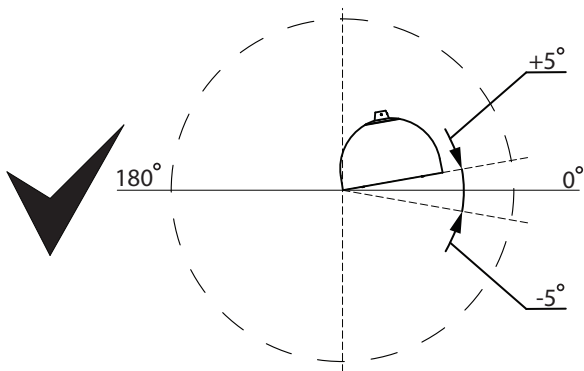

Unacceptable luminaire mounting angle relative to the ground.

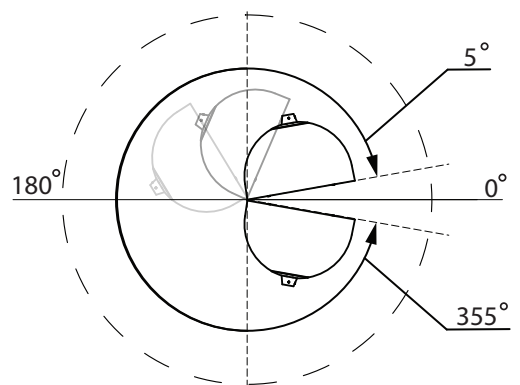

These limitations only apply when mounting the luminaire outdoors!

Šie ierobežojumi attiecas tikai uz gaismekļu montāžu ārā!

Эти ограничения применяются только к установке светильников на открытом воздухе!



**WARNING!**

- Do not touch LED modules!
- Do not put any tools or other items on LED modules!
- In case any LED is physically damaged (example shown below) the warranty is void.

**BRĪDINĀJUMS!**

- Neaiztikt LED moduļus!
- Nenovietot instrumentus vai citus priekšmetus uz LED moduļiem!
- Mehānisku LED bojājumu gadījumā (skatīt piemēru zemāk) garantijas apmaiņa nav spēkā.

**ВНИМАНИЕ!**

- Не прикасаться к LED модулям!
- Не ставить на LED модули инструменты или другие предметы!
- В случае механических повреждений LED (см. ниже) гарантийный обмен не осуществляется.

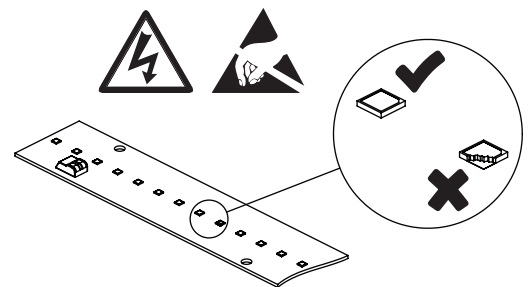



LED	Power	CCT	Risk group	Remarks
Oslon Square	5 ... 100 W	≤ 5700 K	RG1 after TBC m*	Label required
Luxeon 5050	5 ... 100 W	≤ 5700 K	RG1 after TBC m*	Label required
Duris S8	5 ... 100 W	≤ 5700 K	RG1 after TBC m*	Label required

\*The luminaire should be positioned so that prolonged staring into the luminaire at a distance closer than shown in the table above is not expected.

\*Gaismekli jānovieto tā, lai ilgstoša skatīšanās uz to no attāluma, kas mazāks par augstāk esošajā tabulā norādīto, būtu maz iespējama.

\*Светильник должен быть расположен таким образом, чтобы не оставалось возможности продолжительно смотреть в светильник с расстояния, меньше, чем указано в вышеупомянутой таблице.

## Standard configuration

## Standarta konfigurācija

## Стандартная конфигурация

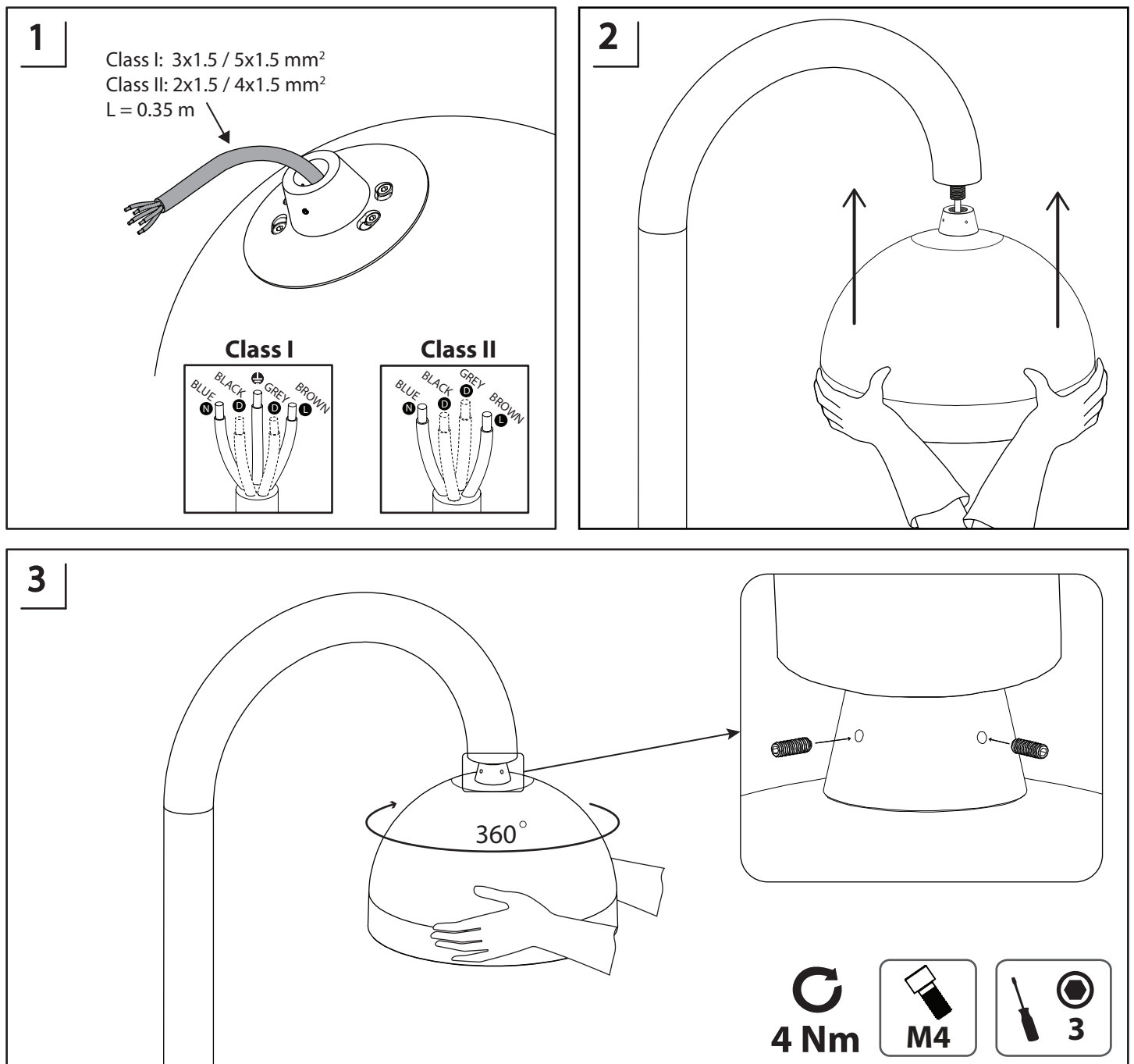

**Configuration with terminal block**  
**Konfigurācija ar spaiļu bloku**  
**Конфигурация с клеммной колодкой**

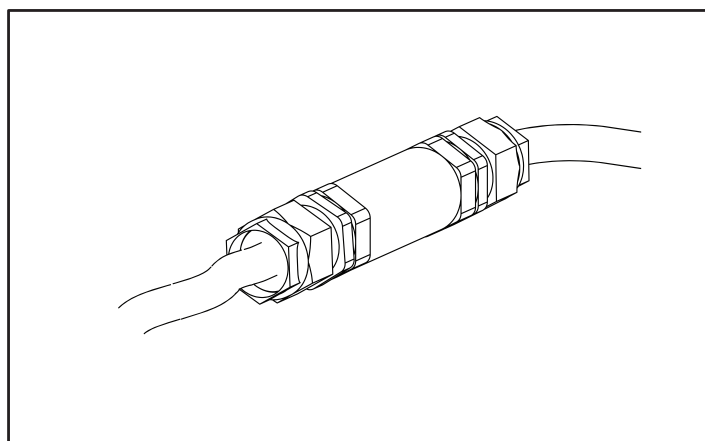
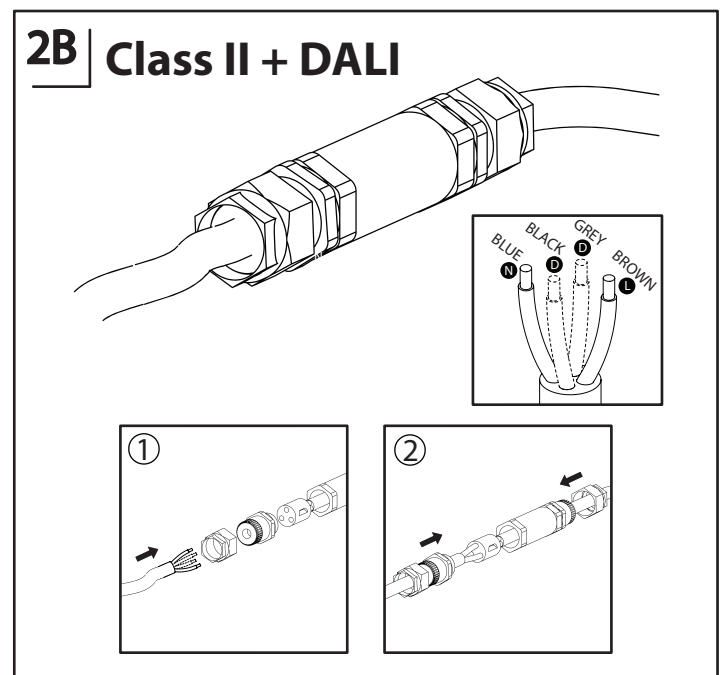
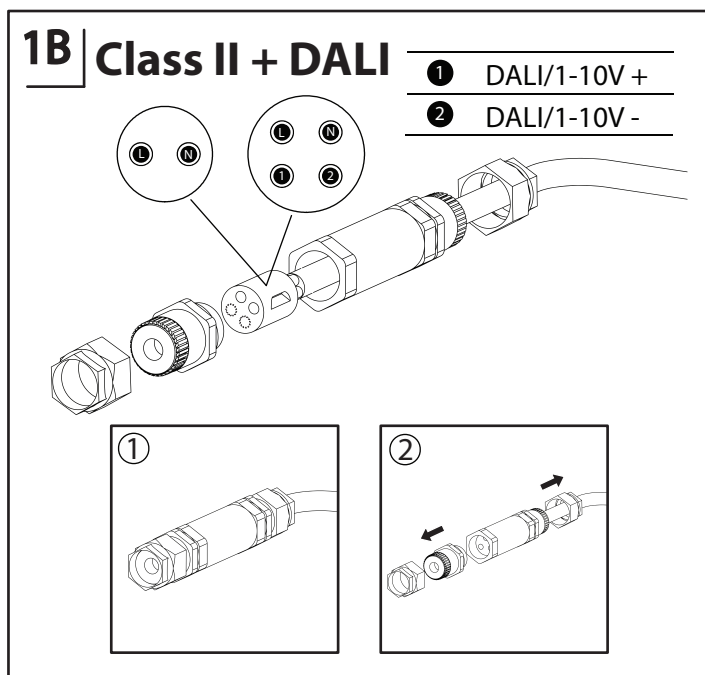
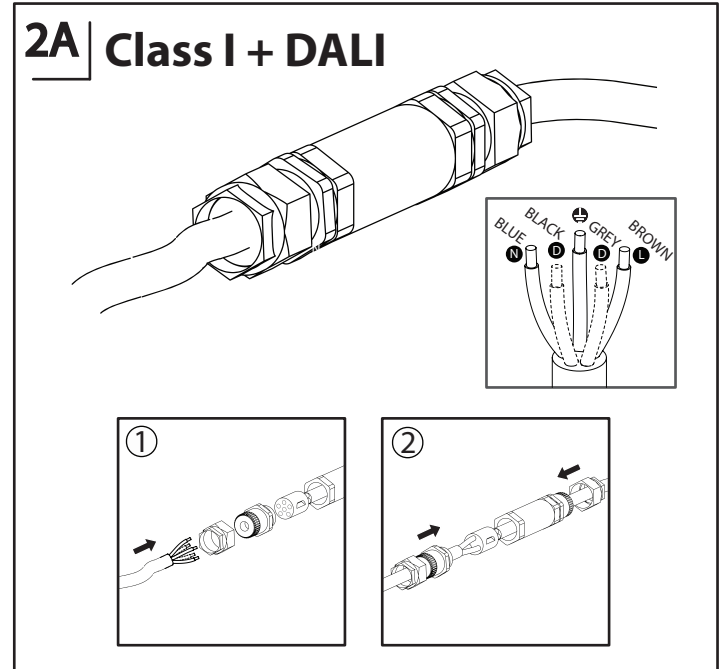
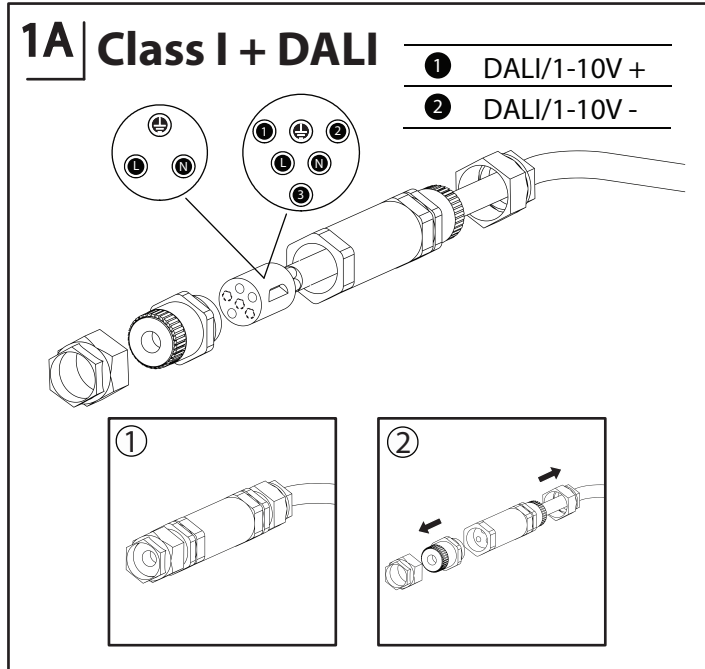

Watertight cable connector has to be ordered separately  
 Ūdensnecaurlaidīgs spaiļu bloks jāpasūta atsevišķi  
 Водонепроницаемая клеммная колодка должна быть заказана отдельно

Article	Description
70000313	2-pole terminal block with PE
70000304	4-pole terminal block with PE
70000314	2-pole terminal block
70000315	4-pole terminal block

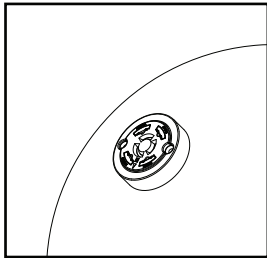

NEMA

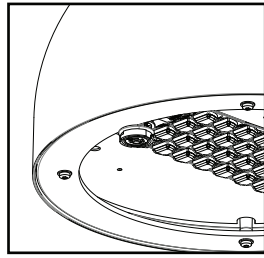

ZHAGA

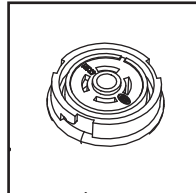

ATTENTION! In case of NEMA/ZHAGA Socket.

IP66 applies only for luminaire body and for connection between luminaire body and NEMA/ZHAGA Socket, and do not apply to any mounted control device and connection between control device and NEMA/ZHAGA Socket.

UZMANĪBU! Gadījumā, ja lieto NEMA/ZHAGA kontaktligzdu.

IP66 klase izpildās tikai gaismekļa korpusam un savienojumam starp gaismekļa korpusu un NEMA/ZHAGA kontaktligzdu. Tā neizpildās nevienai pievienotajai kontroles iekārtai vai arī savienojumam starp NEMA/ZHAGA kontaktligzdu un kontroles iekārtu.

Внимание! В случае использования NEMA/ZHAGA коннектора.

Степень защиты пылевлагозащитности IP66 действительна непосредственно для корпуса светильника и соединения между ним и NEMA/ZHAGA коннектором. Класс IP66 недействителен для подключаемого к NEMA/ZHAGA коннектору оборудованию и его соединения.

### MCB/Inrush current table | Palaišanas strāvu tabula | Таблица пусковых токов

Tridonic LED driver (No dim/ Midnight dimming/ DALI)															
Standard/ High density	In-rush current (peak/duration)	B10A	B13A	B16A	B20A	B25A	B32A	B40A	C10A	C13A	C16A	C20A	C25A	C32A	C40A
4-6 LED, 5-10W	9 A (253 μs)	28	36	44	51	63	81	102	46	60	73	85	106	136	170
6-12 LED, 11-26W	15 A (226 μs)	19	25	30	37	46	59	74	31	41	50	61	76	97	122
12-20 LED, 20-43W	25 A (236 μs)	12	16	20	26	32	41	52	20	26	33	43	53	68	86
20-28 LED, 30-64W	32 A (335 μs)	6	8	10	13	16	20	26	10	13	16	21	26	33	42
28-48 LED, 45-96W	42 A (238 μs)	6	8	10	13	16	20	26	10	13	17	22	27	35	44
48-64 LED, 70-100W	65 A (268 μs)	3	4	5	6	7	9	12	5	7	8	10	12	16	20

Eco		B10A	B13A	B16A	B20A	B25A	B32A	B40A	C10A	C13A	C16A	C20A	C25A	C32A	C40A
4-4 LED, 5-11W	9 A (253 μs)	28	36	44	51	63	81	102	46	60	73	85	106	136	170
4-4 LED, 12-20W	15 A (226 μs)	19	25	30	37	46	59	74	31	41	50	61	76	97	122
4-8 LED, 20-38W	25 A (236 μs)	12	16	20	26	32	41	52	20	26	33	43	53	68	86
8-12 LED, 30-57W	32 A (335 μs)	6	8	10	13	16	20	26	10	13	16	21	26	33	42
12-24 LED, 45-96W	42 A (238 μs)	6	8	10	13	16	20	26	10	13	17	22	27	35	44
24-36 LED, 70-100W	65 A (268 μs)	3	4	5	6	7	9	12	5	7	8	10	12	16	20

Tridonic LED driver (Zhaga)															
Standard/ High density	In-rush current (peak/duration)	B10A	B13A	B16A	B20A	B25A	B32A	B40A	C10A	C13A	C16A	C20A	C25A	C32A	C40A
4-6 LED, 5-11W	8 A (470 μs)	19	25	30	38	47	60	76	31	41	50	63	78	100	126
6-12 LED, 12-26W	15 A (316 μs)	16	21	25	33	41	52	66	26	35	41	55	68	88	110
12-20 LED, 20-43W	20 A (346 μs)	11	14	17	22	27	35	44	18	23	28	36	45	57	72
20-28 LED, 30-64W	28 A (270 μs)	10	13	16	20	25	32	40	16	21	26	33	41	52	66
28-48 LED, 45-96W	38 A (280 μs)	6	8	10	13	16	20	26	10	13	16	21	26	33	42
48-64 LED, 70-100W	56 A (277 μs)	3	4	5	6	7	9	12	5	6	8	10	12	16	20

Eco		B10A	B13A	B16A	B20A	B25A	B32A	B40A	C10A	C13A	C16A	C20A	C25A	C32A	C40A
4-4 LED, 5-11W	8 A (470 μs)	19	25	30	38	47	60	76	31	41	50	63	78	100	126
4-4 LED, 12-20W	15 A (316 μs)	16	21	25	33	41	52	66	26	35	41	55	68	88	110
4-8 LED, 20-39W	20 A (346 μs)	11	14	17	22	27	35	44	18	23	28	36	45	57	72
8-12 LED, 30-57W	28 A (270 μs)	10	13	16	20	25	32	40	16	21	26	33	41	52	66
12-24 LED, 45-96W	38 A (280 μs)	6	8	10	13	16	20	26	10	13	16	21	26	33	42
24-36 LED, 70-100W	56 A (277 μs)	3	4	5	6	7	9	12	5	6	8	10	12	16	20

## Energy efficiency class of contained light source(s)



### Standard

		CRI		
		70	80	90
CCT	1800	F		
	2200	E		
	2500	E		
	2700	D	E	F
	3000	D	E	F
	4000	C	D	E
	5000	C	D	E
	5700	C	D	E
	6500	C		E

### Eco

		CRI		
		70	80	90
CCT	2200	E	F	
	2700	E	E	F
	3000	E	E	F
	4000	D	E	F
	5000	D	E	F
	5700	D	E	F
	6500	D	E	

The light source contained in this luminaire shall only be replaced by the manufacturer or his service agent or a similar qualified person.

Šī gaismekļa gaismas avotu ir atļauts nomainīt tikai ražotājam, tā servisa aģentam vai līdzīgi kvalificētai personai.

Источник света, находящийся в данном светильнике, может быть заменен только производителем или сервисным агентом производителя, либо другим квалифицированным специалистом.



### Caution, risk of electrical shock

### Uzmanību, pastāv elektriskā šoka risks

### Внимание, опасность поражения электрическим током



In case the mains cable is damaged, the luminaire is no longer usable, and it must be either recycled or repaired. The repair can only be performed by VIZULO. Contact either your direct sales manager or look for contact information on our home page - [www.vizulo.com](http://www.vizulo.com).

Gadījumā, ja tīkla kabelis ir bojāts, gaismeklis vairs nav izmantojams, un tas ir jānodod uz pārstrādāšanu, vai uz remontu. Remontu var veikt tikai VIZULO. Sazinieties ar savu tiešo pārdošanas menedžeri vai meklējiet kontaktinformāciju mūsu mājas lapā - [www.vizulo.com](http://www.vizulo.com).

В случае повреждения сетевого кабеля светильник больше не может быть использован, и его необходимо либо переработать, либо отремонтировать. Ремонт может быть выполнен только VIZULO. Свяжитесь с вашим менеджером по продажам или ищите контактную информацию на нашей домашней странице - [www.vizulo.com](http://www.vizulo.com).



## Terms of use and maintenance

Before luminaire is turned on, it should be mounted according with this mounting instruction or any other applicable regulations.

## Mounting instructions

Mounting of luminaire must be performed by a qualified person according with following instructions:

- The warranty of luminaire does not apply, if the mounting of luminaire has been performed in precipitation (rain, snow, hail).
- The warranty of luminaire does not apply, if a control system unauthorized by VIZULO or an inapplicable LED driver has been used to drive the luminaire.
- The warranty of luminaire does not apply, if it has been used in an unsuitable ambient temperature or has been supplied by voltage outside of the specified range.
- The warranty of luminaire does not apply, if the LED driver program has been changed in any way.
- The warranty of the luminaire does not apply, if the logged history data of the LED driver has been deleted without the permission of VIZULO.
- The warranty of luminaire does not apply, if it has been mounted in unspecified angles or upside down (luminaire glass directed up), or it has been completely submerged under water.

## Safety instructions

Any actions with the luminaire must be performed by a qualified person, who is certified according with national regulations and requirements.

To prevent any accidents person installing the luminaire must follow national safety requirements and following instructions:

- The label containing technical parameters of the luminaire has to be studied before the work on it has begun.
- Any luminaire build or design changes are prohibited.
- The luminaire must be used in good technical condition and according with this instruction.
- Only VIZULO authorized spare parts and accessories can be used to repair the luminaire.
- The repair of luminaire has to be performed by a qualified and certified person.

## Maintenance and repair

Luminaire has to be disconnected from electrical grid before it is opened and/or repaired!

- The person working with the luminaire must follow national regulations and legislations that apply to maintenance and testing of electrical or electronic appliances.
- The luminaire may need to be cleaned depending on its environment. Only a damp cloth or a sponge may be used to clean the luminaire. Use only household detergents diluted by water.
- Only VIZULO authorized spare parts may be used for the luminaire.
- Instruction for changing spare parts must be requested from VIZULO and studied before the repair is attempted.
- LED modules, lens and LED drivers can be changed on an installed luminaire, but it is advised to perform this task indoor to avoid water entering the luminaire.
- Spare parts (lens, LED modules and drivers) should be ordered from the information available on the luminaire label.

## Ekspluatācijas uzsākšana

Pirms gaismekļa ieslēgšanas, pārbaudīt tā atbilstību pareizai darbībai un veikt uzstādīšanu atbilstoši šīs montāžas un ekspluatācijas instrukcijas un citiem piemērojamiem noteikumiem.

## Montāžas instrukcijas

Veicot gaismekļa montāžu, ir stingri jāievēro montāžas instrukcijā iekļautā informācija un noteikumi:

- Gaismekļa garantija nav spēkā, ja gaismekļi tiek montēti nokrišņu (lietus, sniega, krusas) laikā.
- Gaismekļa garantija nav spēkā, ja tika izmantotas VIZULO neautorizētas vadības sistēmas vai tika izmantots neatbilstošs barošanas bloks.
- Gaismekļa garantija nav spēkā, ja tas tika ekspluatēts neatbilstošos temperatūras un elektrības pieslēguma apstākļos.
- Gaismekļa garantija nav spēkā, ja ir veiktas barošanas bloku programmas iestatījumu izmaiņas vai tā tikusi dzēsta neinformējot VIZULO.
- Gaismekļa garantija nav spēkā, ja tikuši dzēsti vai mainīti barošanas bloka vēstures ieraksti.
- Gaismekļa garantija nav spēkā, ja tas tika uzstādīts un ekspluatēts neatbilstošos montāžas leņķos, tika uzstādīts otrādi (ar stiklu uz augšpusi) vai tika pilnīgi iegremdēts ūdenī.

## Drošības instrukcijas

Darbam ar gaismekli drīkst tikt pielaisti tikai atbilstoši apmācīts un valsts tiesību aktiem atbilstoši sertificēts personāls.

Lai novērstu nelaimes gadījumu rašanos, ievērot valsts drošības noteikumus un šīs drošības instrukcijas.

- Ir jāiepazīstas un jāievēro tehniskie parametri, kas ir norādīti gaismekļa marķējumā.
- Ir aizliegts veikt gaismekļa konstrukcijas un dizaina izmaiņas.
- Gaismeklis ir jāekspluatē labā tehniskā stāvoklī un atbilstoši šīm instrukcijām.
- Gaismekļa remontam ir atļauts izmantot tikai VIZULO autorizētas detaļas un piederumus.
- Gaismekļa remontu drīkst veikt tikai atbilstoši apmācīts un sertificēts personāls.

## Apkope, apkalpošana un remonts

Atvienojiet gaismekli no elektrotīkla pirms tā atvēršanas vai veicot remontu!

- Ievērojiet nacionālos noteikumus un valsts tiesību aktus, kas ir piemērojami elektrisko aparātu uzturēšanai, apkalpošanai un testēšanai.
- Atkarībā no vides apstākļiem gaismekli var būt nepieciešams tīrīt. Tīrīšanai izmantojiet tikai mitru lupatiņu vai sūkli. Izmantojiet tikai ierasto sadzīves mazgāšanas šķidrums atšķaidītu ar ūdeni.
- Izmantojiet tikai VIZULO autorizētas oriģinālās rezerves daļas.
- Lai kvalitatīvi veiktu rezerves daļu nomaiņu, ir jāpieprasa un jāiepazīstas ar VIZULO izstrādātām rezerves daļu nomaiņas instrukcijām.
- Gaismas diodes, lēcas un barošanas bloki var tikt nomainīti uz vietas, bet lai izvairītos no ūdens iekļūšanas to ir ieteicams veikt telpās.
- Lūdzu pasūtīt jaunu LED moduli, lēcas vai barošanas bloku, izmantojot informāciju gaismekļa marķējumā.